

CC1A-T3A

SM Crystal -55+125°C with Sn/Ag/Cu plated pads

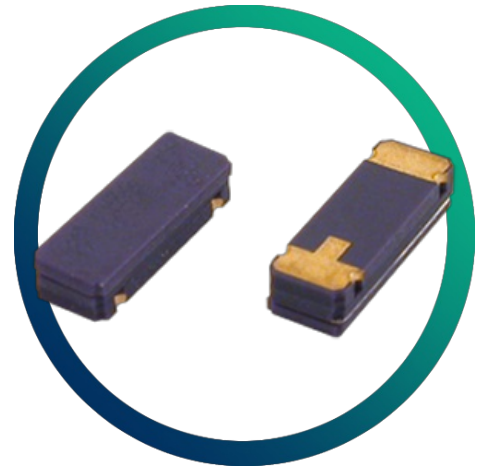

- Fundamental mode
- High shock & vibration resistance
- Military temperature range -55+125°C option
- Low power consumption

CONFIGURABLE OPTIONS

Parameter	Option Code
-----------	-------------

PACKAGE DRAWING

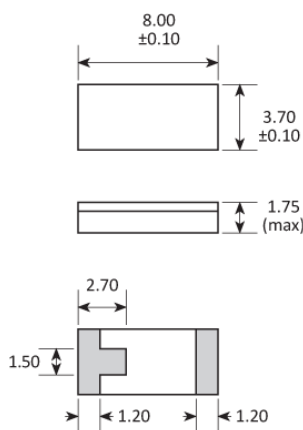

SOLDER PAD LAYOUT

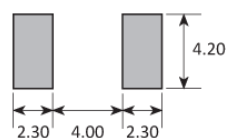

TOP VIEW

Dimensions in mm

ORDERING INFORMATION

To request a quotation for the CC1A-T3A please use the configurable options form to choose the options you require and then submit your configured product to our team. Our expert advisers are always happy to help with your requirements and can be contacted on +44 1460 256 100 or at sales@golledge.com.

Following product selection you will be issued with a seven character Golledge part number. Your Golledge part number is the internationally accepted Golledge manufacturing part number (MPN) that should be used for all project documentation, including bills of materials (BoMs) and purchase orders.

If you have any queries regarding any of our documentation our dedicated sales team will be happy to help.

TAPE & REEL SPECIFICATION

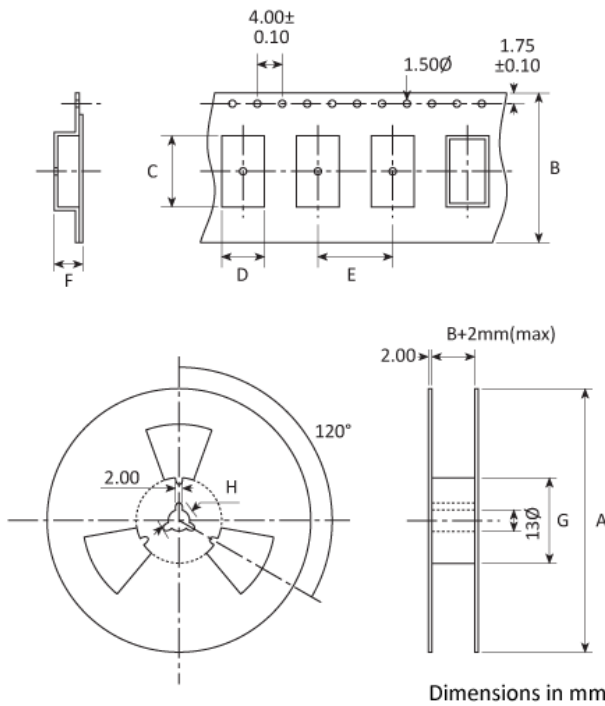

A:178* B:16 C:8.5 D:4.4 E:8 F:2 G:80 H:21

*Larger reel size available. Please ask for details

CONSTRUCTION

Ceramic base and lid

HANDLING & STORAGE



Human Body Model (HBM) 1A (250V to < 500V)



Moisture Sensitivity Level (MSL): 1

COMPLIANCE



Lead-free (< 0.1% by weight)



RoHS compliant with no exemptions.