

SAW Filter 2375.0MHz
Part No: MP01518

Model: TA0819A
Rev. No: 2

A. MAXIMUM RATING:

1. Input Power Level: 10dBm
2. DC voltage: 3V
3. Operating Temperature: 0°C to +80°C
4. Storage Temperature: -40°C to +85°C

B. ELECTRICAL CHARACTERISTICS:

Item	Unit	Min.	Typ.	Max.
Center frequency Fc	MHz	-	2375	-
Insertion loss(2360 ~ 2390MHz) IL	dB	-	1.8	2.5
Insertion loss(2310 ~ 2360MHz) IL	dB	-	2.8	4.5
Insertion loss(2300 ~ 2310MHz) IL	dB	-	4.8	6.0
Insertion loss(2390 ~ 2400MHz) IL	dB	-	2.8	4.5
Amplitude ripple (2360 ~ 2390MHz)	dB	-	0.6	1.0
Amplitude ripple (2310 ~ 2360MHz)	dB	-	1.1	1.5
Amplitude ripple (2300 ~ 2310MHz)	dB	-	1.7	2.5
Amplitude ripple (2390 ~ 2400MHz)	dB	-	1.1	2.0
VSWR (2300 ~ 2400MHz)			1.85	2.5
Attenuation (Reference level from 0dB)				
DC ~ 2200MHz	dB	23	29.5	-
2452 ~ 2472MHz	dB	45	62	-
2472 ~ 4000MHz	dB	30	35	-
Temperature Coefficient	ppm/°C	-	-36	-
Source impedance Z _S	Ω	-	50	-
Load impedance Z _L	Ω	-	50	-

SAW Filter 2375.0MHz

Model: TA0819A

Part No: MP01518

Rev. No: 2

C. MEASUREMENT CIRCUIT:

50Ω Test circuit (single-ended / single-ended)

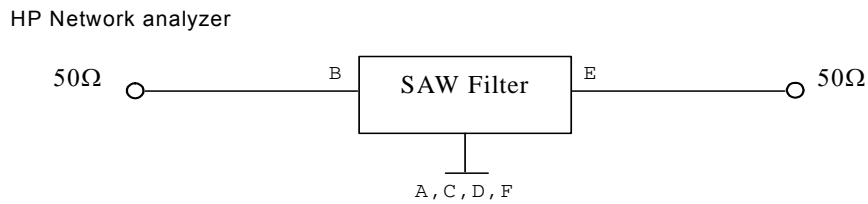

D. OUTLINE DRAWING:

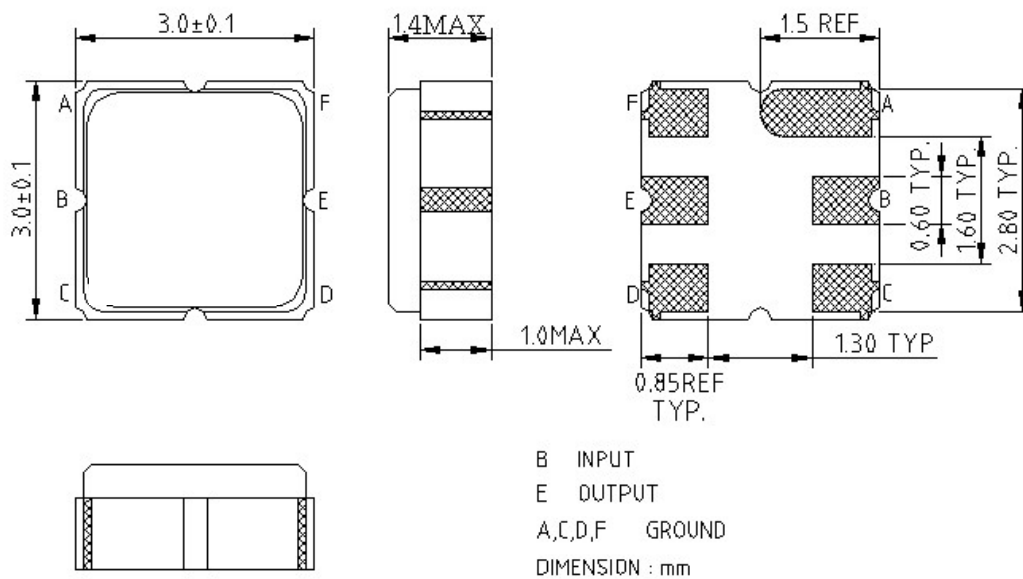

E. PCB FOOTPRINT:

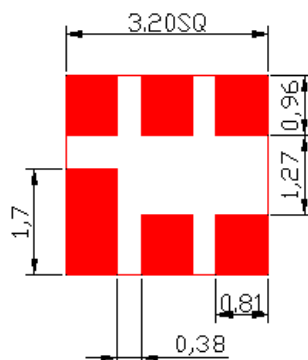

SAW Filter 2375.0MHz
Part No: MP01518

Model: TA0819A
Rev. No: 2

F. FREQUENCY CHARACTERISTICS:

1. Transfer function

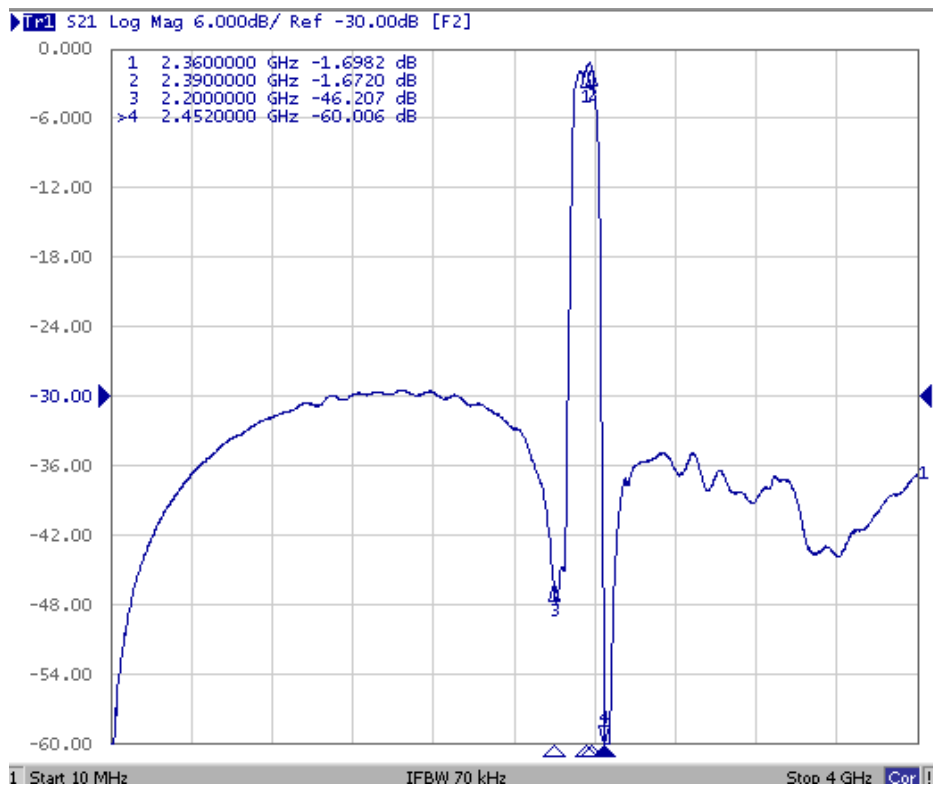
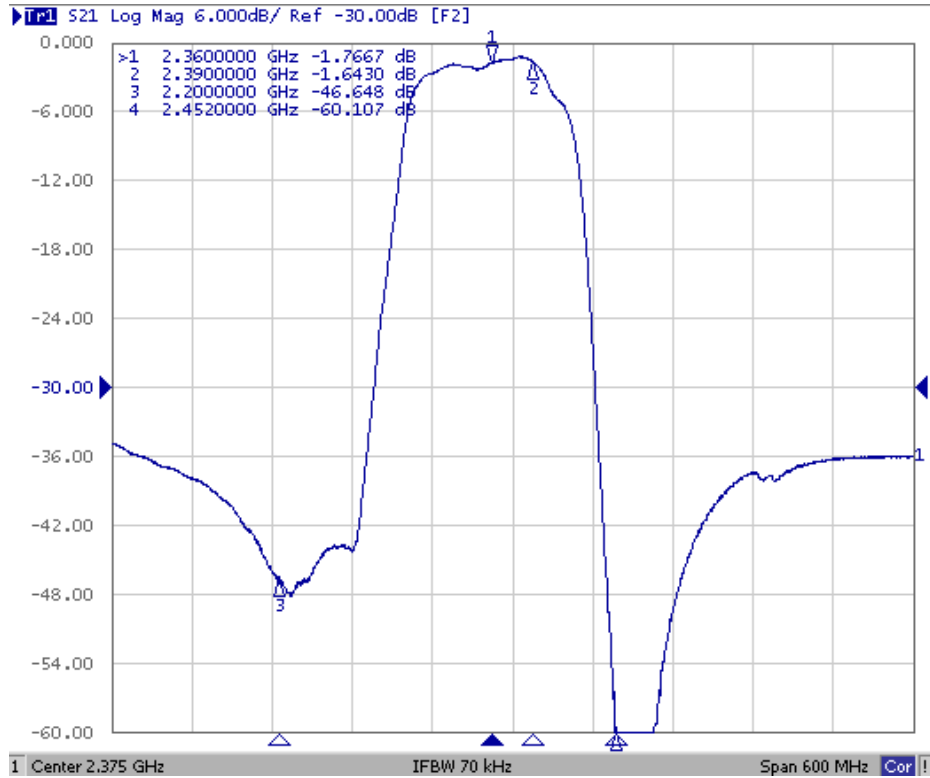

SAW Filter 2375.0MHz
Part No: MP01518

Model: TA0819A
Rev. No: 2

2. Reflection Functions

S11

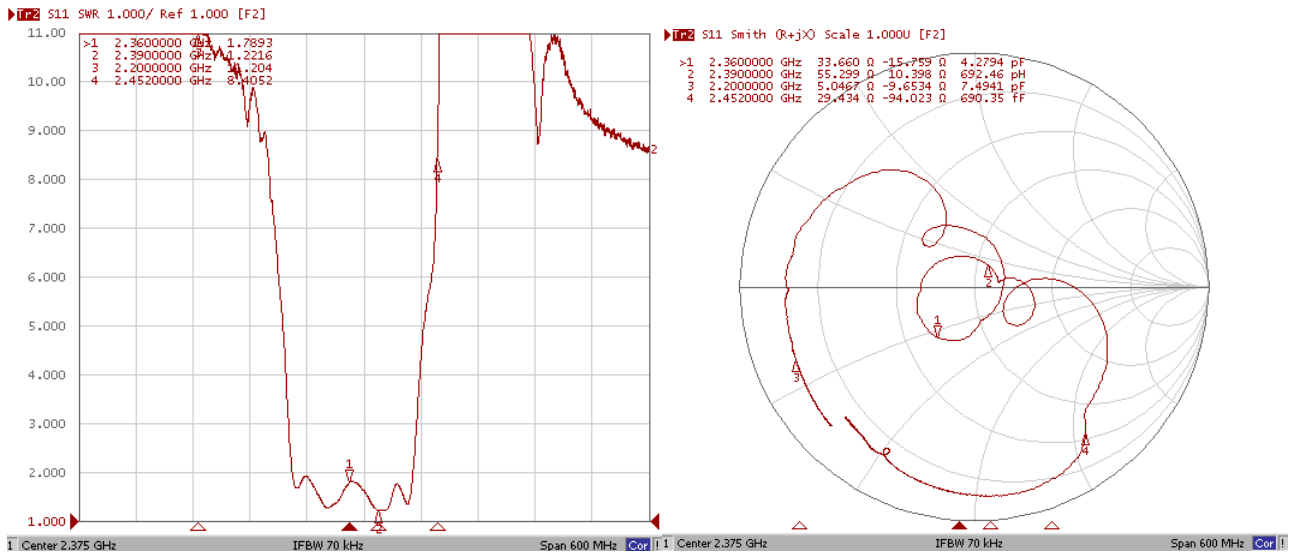

S22

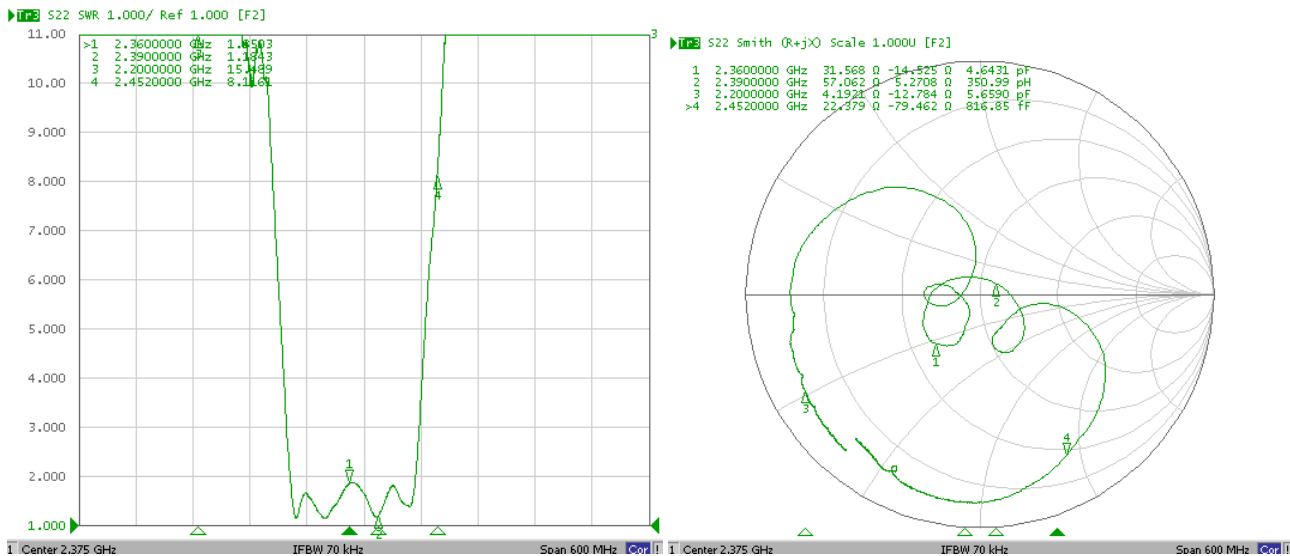

SAW Filter 2375.0MHz
Part No: MP01518

Model: TA0819A
Rev. No: 2

G. PACKING:

1. Reel Dimension

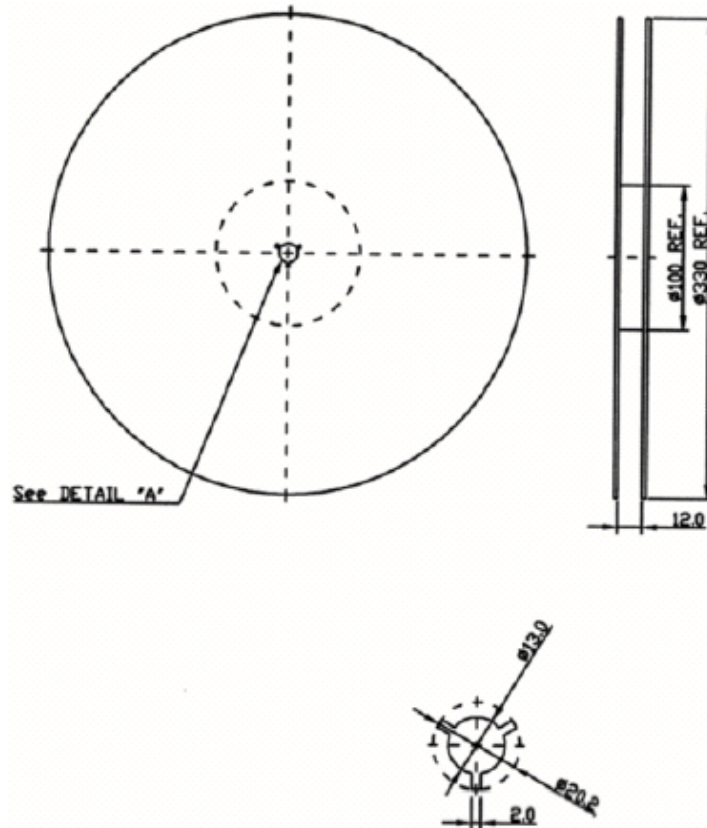

2. Tape Dimension

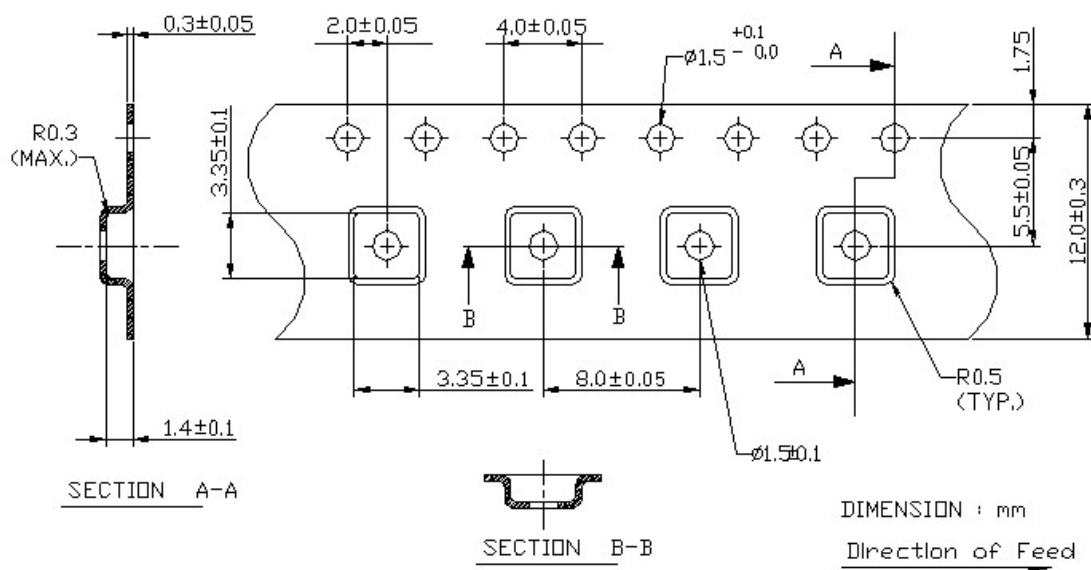

SAW Filter 2375.0MHz
Part No: MP01518

Model: TA0819A
Rev. No: 2

H. RECOMMENDED REFLOW PROFILE:

